

## OptiCool Windows and Objectives

### X210 – Low Working-Distance Top Window

A low working-distance (LWD) top window is available for use with external microscope objectives. The standard OptiCool top windows have a minimum working distance of about 15 mm between the top of the outer window and the underside of the inner shield window. With the LWD top window, this distance can be reduced to about 3 mm. This close spacing is achieved with a 0.75 mm thick outer window and a 0.40 mm thick inner window. The outer window is UV fused silica and is epoxied into the window frame to create a low profile, low stress, durable seal. The inner window is also UV fused silica and is held in place with spring clips that minimize stress in the glass at low temperatures and allow for easy replacement or removal. Both windows have a thickness tolerance of  $\pm 0.01$  mm and together have a combined thickness of 1.15 mm. This thickness of fused silica matches the optical thickness of 1.10 mm of crown glass, a common correction thickness available in many objectives. The windows can be ordered uncoated, with a 650-1050 nm AR coating, or with a 400-800 nm AR coating. Also, Zinc Selenide windows (both 1 mm thick) are available for use in the Mid-Infrared.

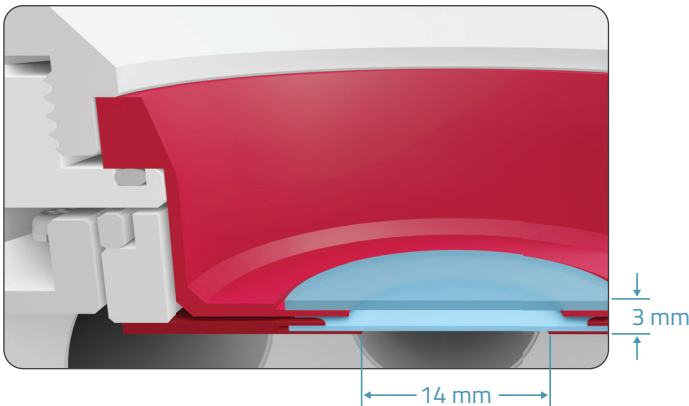

*Installed Low Working Distance Window with 0.75 mm-thick outer window and 0.40 mm-thick inner window.*

The clear window diameter at the shield is 14 mm and, because of the high homogeneity of the magnet, the field error across the full diameter at the window is less than 0.3%. While the shield window is required for the ultimate base temperature of your sample, you can remove the shield window if base temperature is not critical. A spacing less than 1 mm can be achieved between the outside of the cryostat and your sample if the shield window is removed.

Above the window, you can directly mount objectives at close spacing using the included flared window clamp. The clamp has standard Thorlabs SM3 ID threads allowing an objective to be mounted using off-the-shelf adaptor rings. This clamp can be removed and adjusted while the system is cold and under vacuum, allowing the use of multiple objectives during a single cooldown.

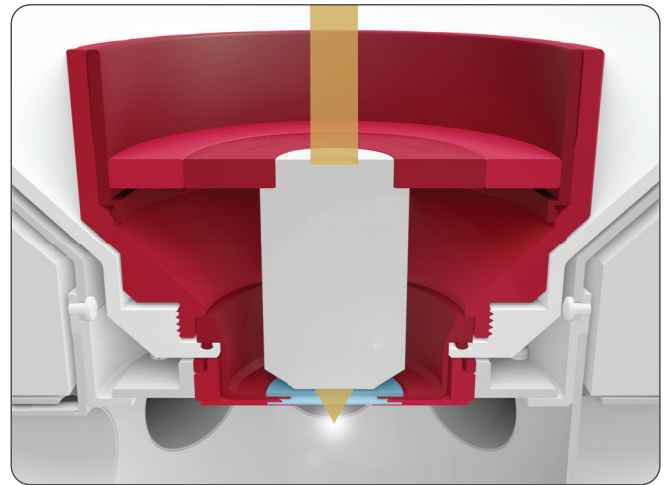

*Cross-sectioned view of the flared window clamp with adapter rings and an external objective mounted close to the window.*

### X200/X202 – Internal Microscope Objective

Many experiments require a high-quality, high-NA objective positioned close to the sample. To address this need, Quantum Design offers two vacuum compatible objective options. The **X200** option has a 0.75 NA Zeiss 100x LD EC Epiplan-Neofluar objective with a working distance of 4 mm, giving a free working distance of 3 mm between your sample and the cold shield aperture. The **X202** option has a 0.9 NA Zeiss 100x EC DIC Epiplan-Neofluar objective with a working distance of 1 mm. Use this option where maximum light gathering is a priority. When used with the X201 Mounting Hardware (included), these objectives are maintained in vacuum at room temperature to provide the optimal environment to take full advantage of their high-performance designs.

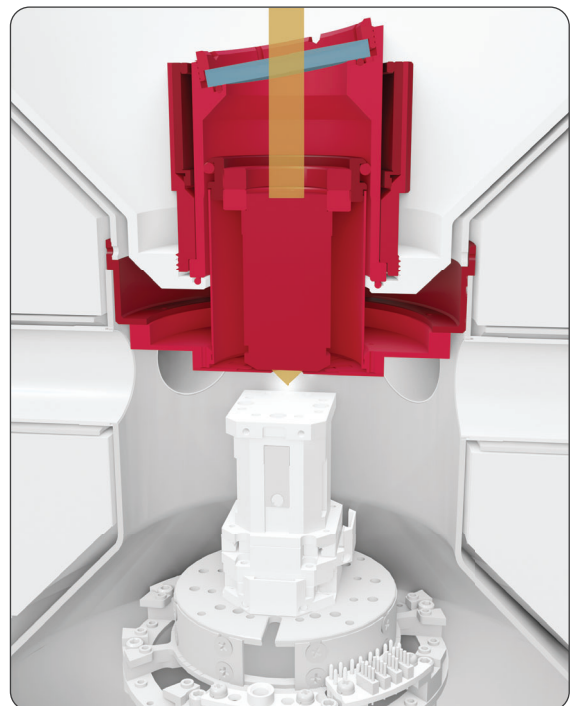

*Zeiss objective and nanopositioners in a cross-sectioned view of the OptiCool sample volume.*

### X201 – Internal Objective Mounting Hardware

Quantum Design offers the hardware from the X200 and X202 options (see page 9) without the objective as a separate kit so you can mount your own objectives. The hardware is highly configurable to allow many different types of objectives to be installed. The mounting hardware can be configured to maintain the objective at room temperature or to cool it to shield or sample temperature for the lowest possible working distance. You can mount a room temperature objective in vacuum using either an orifice for the best optical performance, or a shield window for the lowest base temperature. With a cold objective, both the lowest base temperature and highest NA are possible. Non-magnetic, vacuum compatible objectives are recommended for room temperature mounting, and cryogenic compatible objectives for cold mounting.

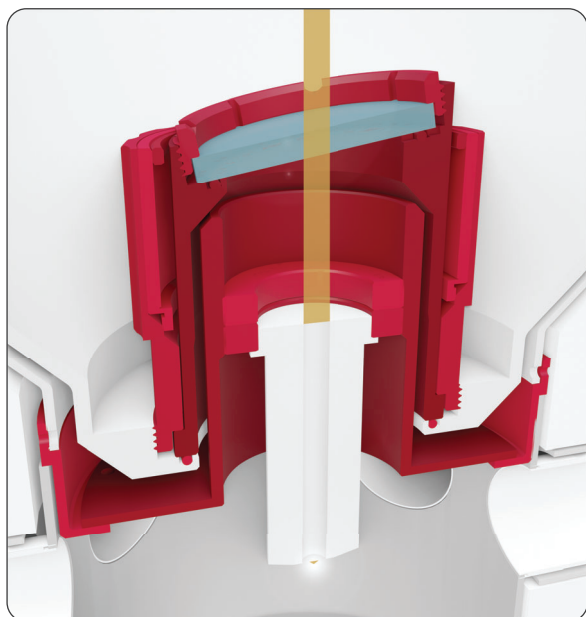

*Mounting hardware allowing use of customer's own "top window" objectives.*

### X245 – Large Top-Volume Housing Kit

The cryostat's top vacuum housing and shield adapter can be replaced to create additional space in the sample volume. With this kit the top window is moved up 57 mm to provide extra volume above the magnet center line for additional experimental hardware or optical components.

### X240 – Bottom Access Window

A bottom window can be added to the OptiCool cryostat allowing transmission measurements along the magnet-axis, perpendicular to the surface of the optical table. This option replicates the top window interface within the bottom vacuum plate and shield plate, allowing use of the same windows and hardware. This option along with the top window allows for a 41 mm diameter clear volume through

the center of the cryostat. This option includes the X242 Cryostat Riser for gaining access to the bottom window.

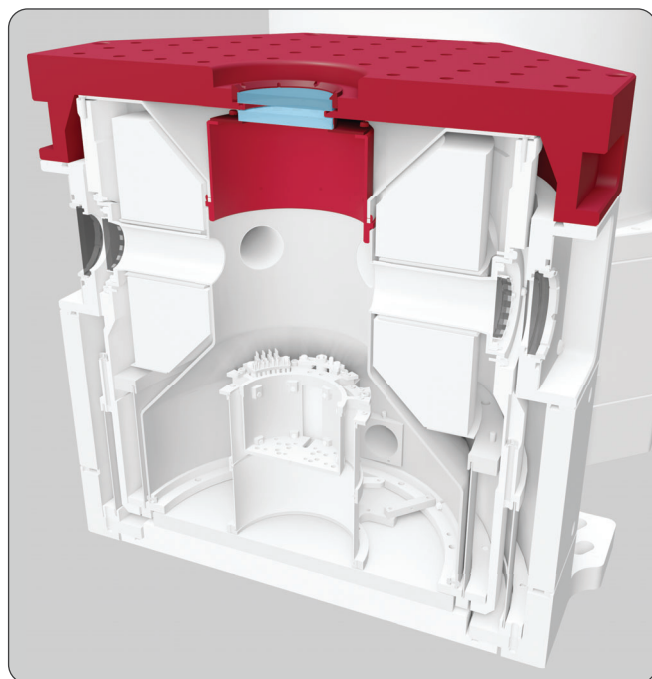

*Cross-sectioned view of the OptiCool cryostat showing the Large Top-Volume Housing Kit installed. This provides an additional 57 mm of overhead beyond the standard sample volume.*

### X242 – Cryostat Riser

The cryostat riser is a rigid platform that lifts the cryostat 175 mm above the surface of the optical bench. Use the X242 Cryostat Riser to gain access to the bottom window. This riser is included with the X240 Bottom Access Window option.

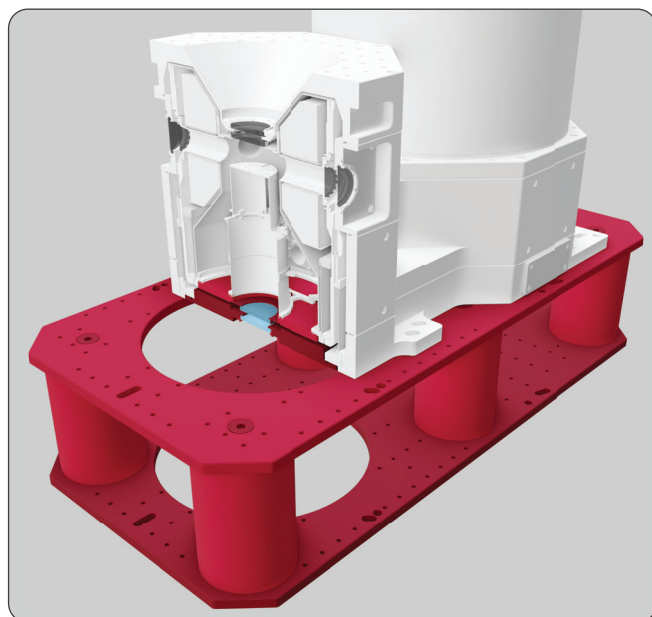

*OptiCool cryostat equipped with bottom window mounted on top of the riser platform.*