

The Pinnacle of Cryogenic Nanopositioning



KEY FEATURES

- Motion performance specified at the top of a fully-integrated 3-axis stack:
 - Bidirectional repeatability
 - Multi-axis runout
- Automatic temperature-dependent parameter optimization
- Includes a 2-year warranty

The Rook stands out as the only nanopositioning system available with multi-axis runout and bidirectional repeatability specified at the sample location across the full travel range, delivering performance achievable from anywhere within the motion envelope.

To distinguish even further, The Rook's performance specifications are measured and validated at the top of the stack in a 4 Kelvin environment while mounted in an operational 100mm Cryostation platform. This mirrors typical laboratory use cases and uniquely provides users with a new peak level of understanding of their sample's expected three-dimensional motion.

Coupled with the reliability of a robust positioner that stands up to everyday handling and operation, Montana Instruments has set a new standard of nanopositioning performance. In addition, the motion system is integrated into Montana Instruments' Galaxy SW and touchscreen architecture for intuitive control and single-access-point scripting to the entire cryogenic ecosystem.



The Rook – Open Loop

- All units include proprietary flex-link to maximize thermal performance

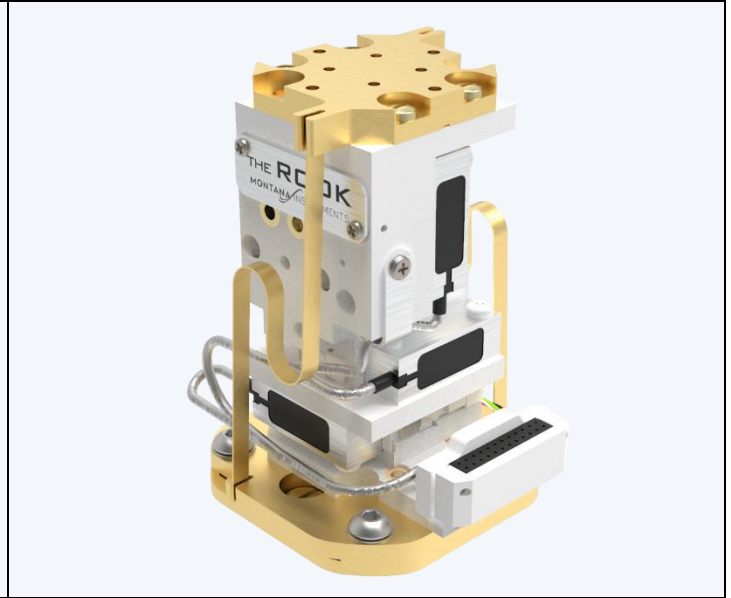

The Rook – Closed Loop

- Compatible with all standard adapter and sample mount options

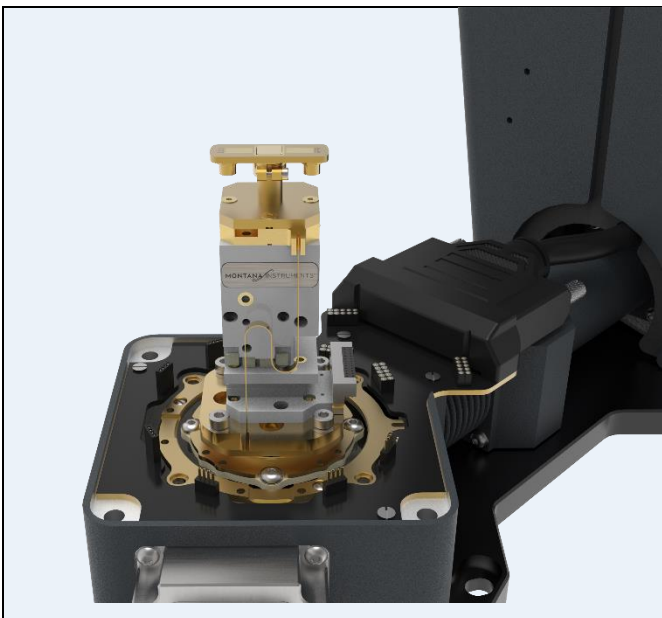

MI's Standard Nanopositioner

- The Rook configured in a CryoAdvance 50 with other standard options can support a wide variety of applications

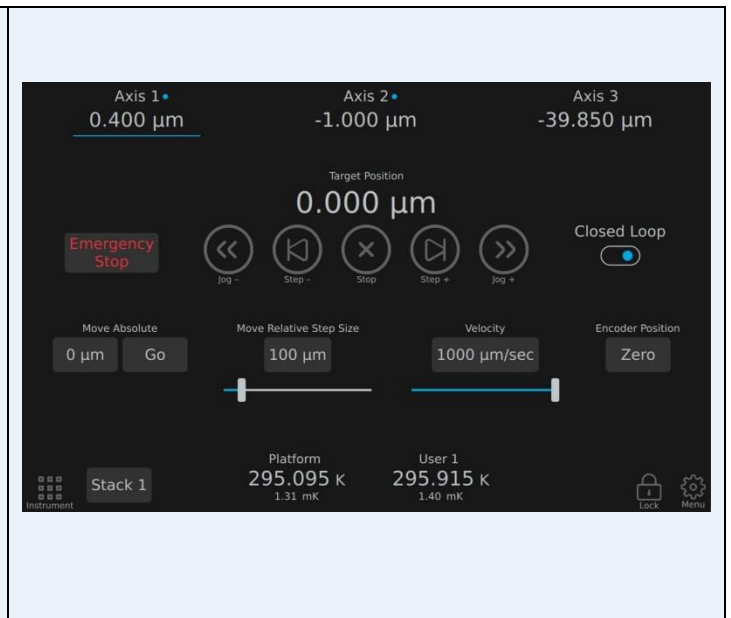

Touchscreen User Interface

- Seamless integration with Galaxy software for comprehensive motion control and scripting

Specifications ^{1, 2}

Performance Specifications	
Travel Range (XYZ)	5 x 5 x 5 mm
Sensor resolution ³	50 nm
Multi-axis runout (Across full travel)	< 8.0 μm
Bidirectional 3-axis point repeatability ³ (Across full travel)	< 10.0 μm
Payload	400 g ⁴
Drive velocity, maximum	1.0 mm/sec
Open loop mode minimum incremental motion	40 nm
Closed loop mode minimum incremental motion	100 nm
General	
Environmental Operating Range	3.2 K to 300 K
Vacuum Pressure range	1E-7 Torr to Ambient
Positioner dimensions (Not including flex-link or stage wiring)	24 x 24 x 51 mm (L x W x H)
Multi-stack configuration	Available, limited by sample space
Drive modes	Open loop & closed loop

¹ All values specified at 4K unless otherwise stated; all metrology is completed with the Rook installed in an operational Montana Instruments 100mm Cryostation

² Some CryoAdvance50 sample chamber configurations may not conform to all specifications

³ Closed loop only

⁴ Up to 400 grams is possible with included preload springs; performance to specifications is not guaranteed when spring is in use. With no spring the payload limit is 100 grams

Dimensions

Open loop and closed loop pictured below; overall dimensions are identical for both versions.

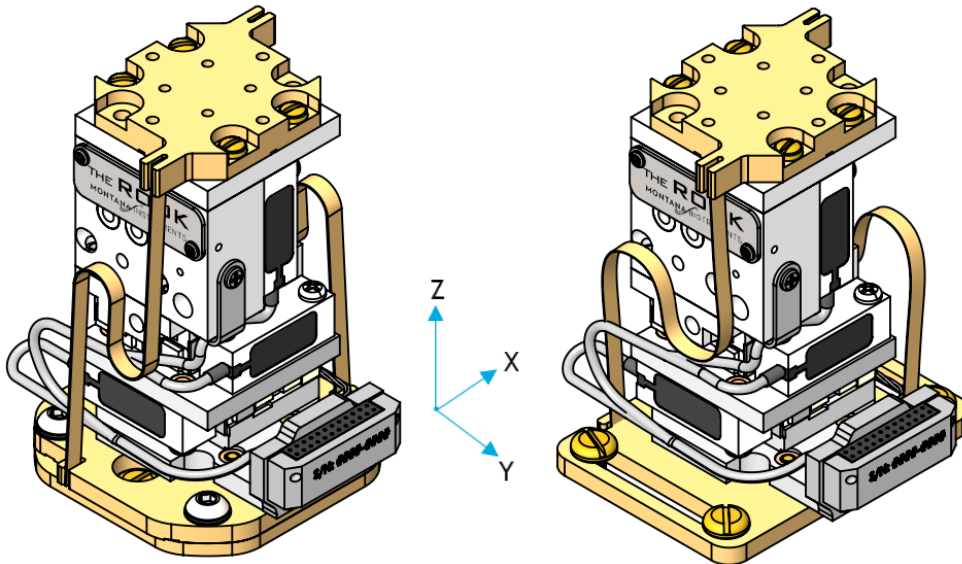

CA50/100 FLEX LINKS
INSTALLED

s200 FLEX LINKS
INSTALLED

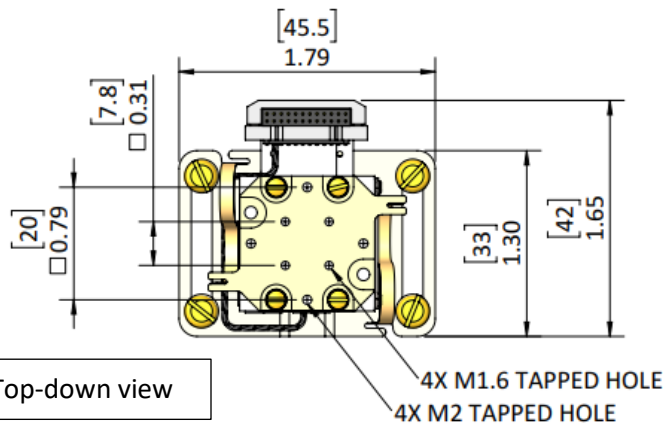

S200 Top-down view

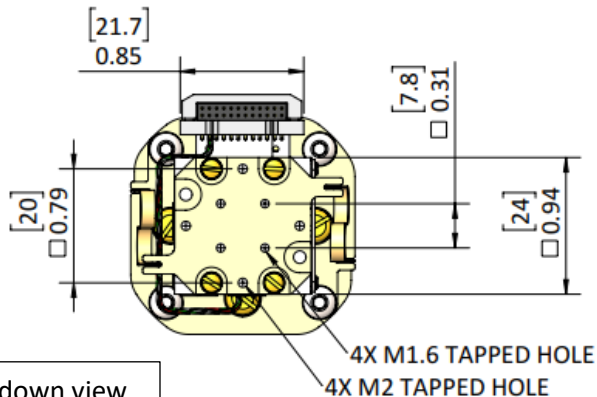

CA50/CA100 Top-down view

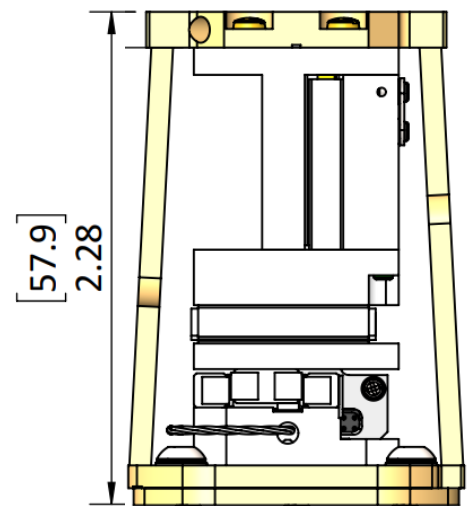

Profile – all versions